

Rev.	Date	Affects		Change descri
		Geom.	Dwg	
H	2010.07.05		x	Change tolerance

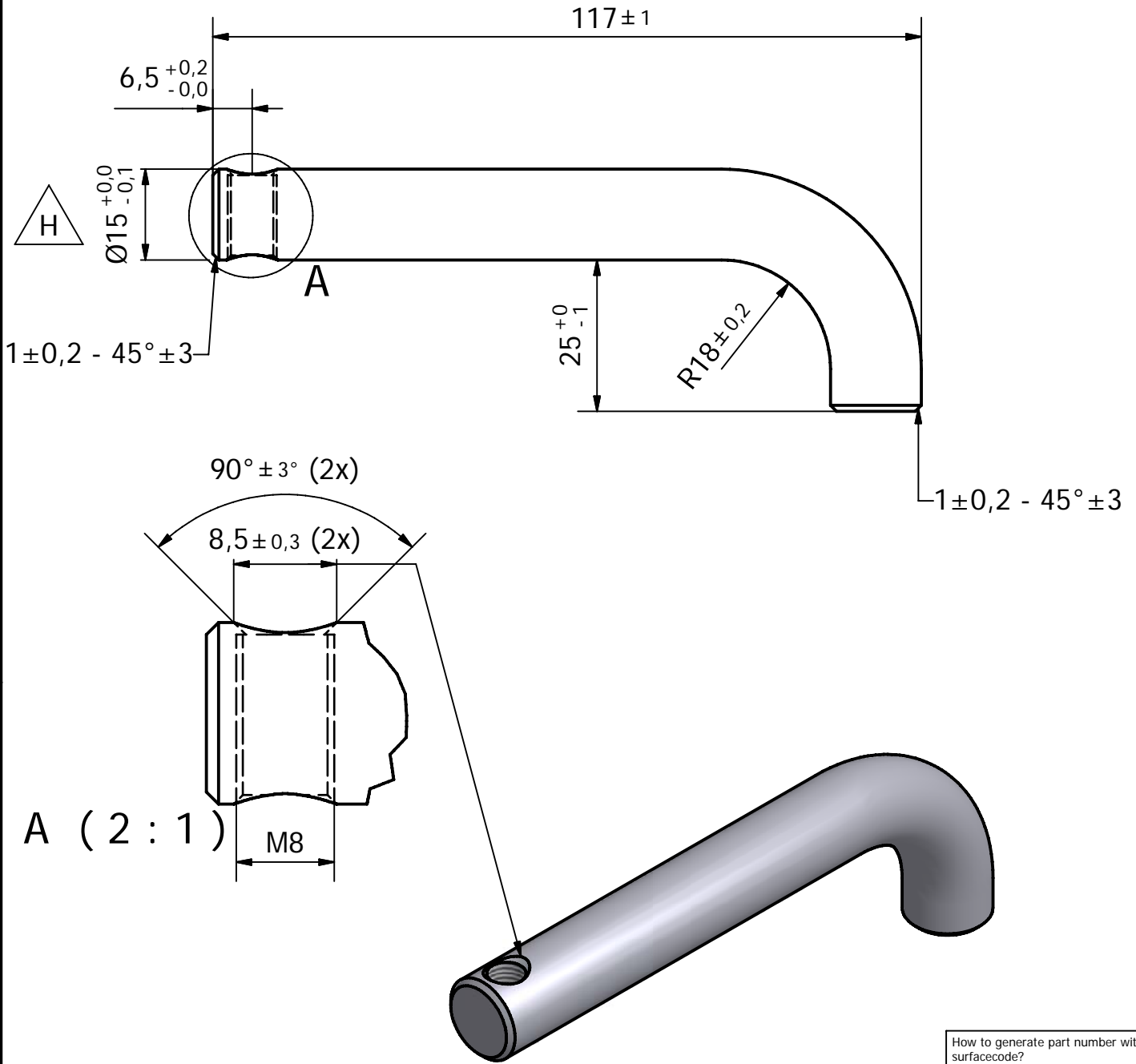

Part must be free from burrs

How to generate part number with surfacecode?  
**Example:**  
 This part: 4522125xx  
 xx will tell the type of surface.  
 For choice of surface, see document J-476761

Master Sample - reference see document: J-476778

Material: HPb 59-1

Alloy elements/Chemical composition							
	Cu	Al	Fe	Pb	Sb	Bi	P
min.	57	-	-	0,8	-	-	-
max.	60	0,2	0,5	1,9	0,01	0,003	0,02

Brass Part

\* General dimensions, details features and design must be determined directly from the 3D CAD model file.  
 \* After polishing there should not be any contamination on the surface.

Material Description				
Material	Min. Yield strength, $R_{0,2}$ [N/mm <sup>2</sup> ]	Min. Tensile strength, $R_m$ [N/mm <sup>2</sup> ]		
Brass	390	500		
1984-08-28	POA			1:1
Date	Drawn by	Checked by	Approved by	Scale
<b>Grip</b>				
4522125			Revision	Page no.
			H	1/1

European projection  
  
 THIS DRAWING CONTAINS RESTRICTED INFORMATION. IT SHALL NOT BE COPIED, OR THE INFORMATION DISCLOSED WITHOUT THE PRIOR WRITTEN PERMISSION OF VINGCARD.