

NOTES: UNLESS OTHERWISE SPECIFIED

1. INTERPRET DRAWING PER ASME Y14.5 - 2009
2. PARTS TO BE CLEAN, FREE OF OIL, GREASE, DIRT AND LOOSE PARTICLES

1. 图纸解释依照ASME Y14.5-2009
2. 零件需要清洁, 除油、油脂, 灰尘除锈和喷砂处理

材料: 316L不锈钢
表面处理: 钝化

预计年用量: 5000件
报价: 1000件; 2500件; 5000件

REVISION BLOCK				
REV	ECD	DESCRIPTION	DATE	CHANGE APPROVAL
A	1033	ENGINEERING RELEASE	10/12/2017	MSJ/W
B	1042	ADDED HEX HEAD	12/27/2017	MSJ/W

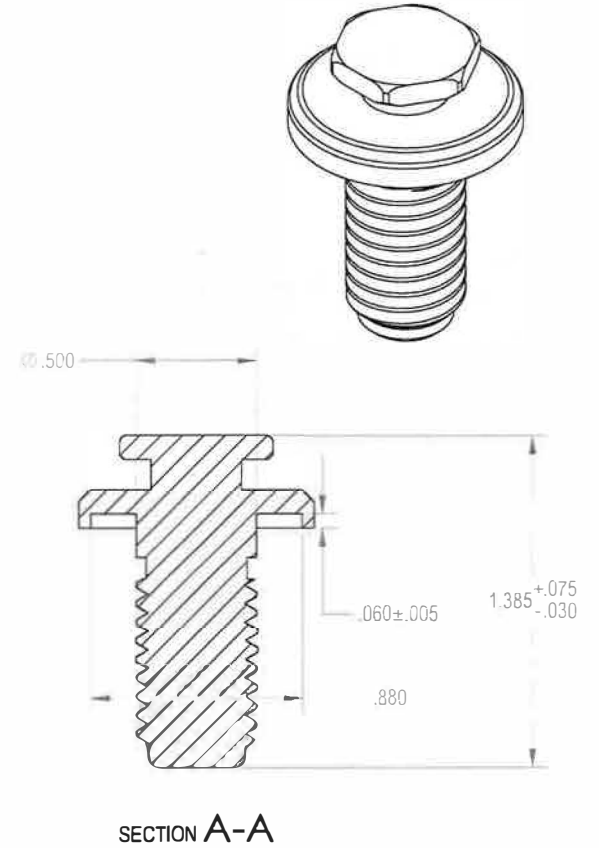
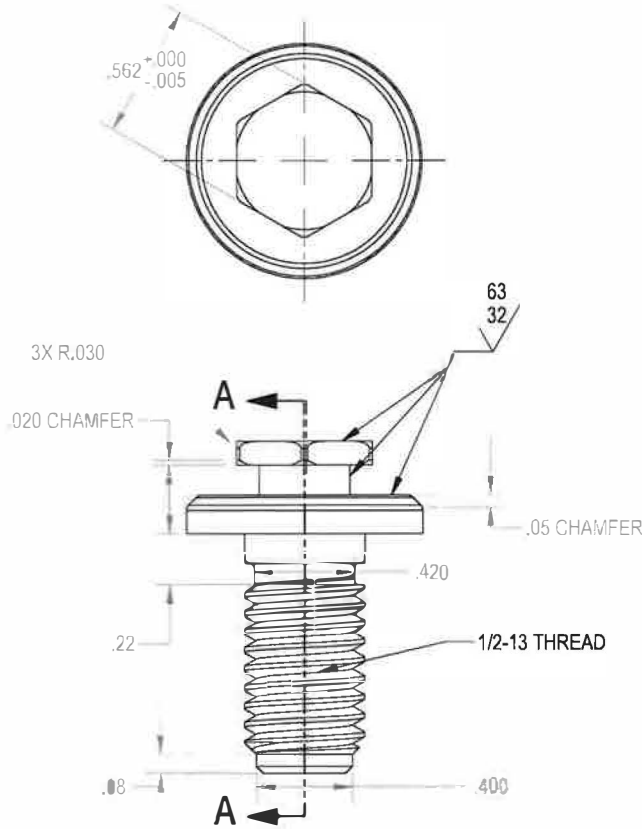
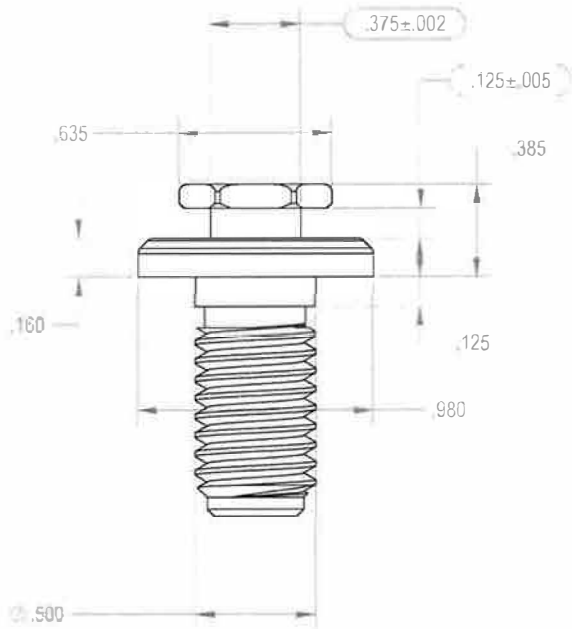

公差尺寸:
两位: ±0.76mm
三位: ±0.254mm
角度: ±5°
分数: ±1/16"

TOLERANCE BLOCK DIMENSIONS ARE IN INCHES		PROPRIETARY		TITLE	
DECIMALS .X ±.1	ANGLES ±.5°			SCREW:STUD KEYHOLE 1/2-13	
DECIMALS .XX ±.03	FRACTIONS ± 1/16"			SIZE	DWG NO.
DECIMALS .XXX ±.010				B	6570-354
MATERIAL	STAINLESS STEEL - GRADE 316L	APPROVALS	DATE	SCALE	NEXT ASSY.
FRESH	PASSIVATED	DRAWN BY	10/31/2017	2:1	
		APPROVED BY	12/27/2017		
THIRD ANGLE PROJECTION		Jeremy Wilson			
				SHEET 1	OF 1
				REV B	